



Products may differ from illustrations shown

This frame trolley for Euro-sized loads has an electric drive aid and can therefore be easily moved by hand. It is perfect for trolley train transportation when combined with our electric gantry trolley. The cockpit is optionally removable and can be used on different trolleys which provides for increased flexibility and efficiency. This offers an interesting possibility to integrate it into a trolley train system.

ELECTRIC DRIVE SYSTEM

EURO SIZE

ERGONOMIC

VERSATILE

COMPATIBLE WITH PORTAL TROLLEY

Model	ART.-NO.	L x W x H outside	usable area height
Frame Trolley with Electrical Support	521-6000-363	approx. 1240 x 1025 x 1235 mm	262 mm

FRAME TROLLEY WITH ELECTRICAL SUPPORT

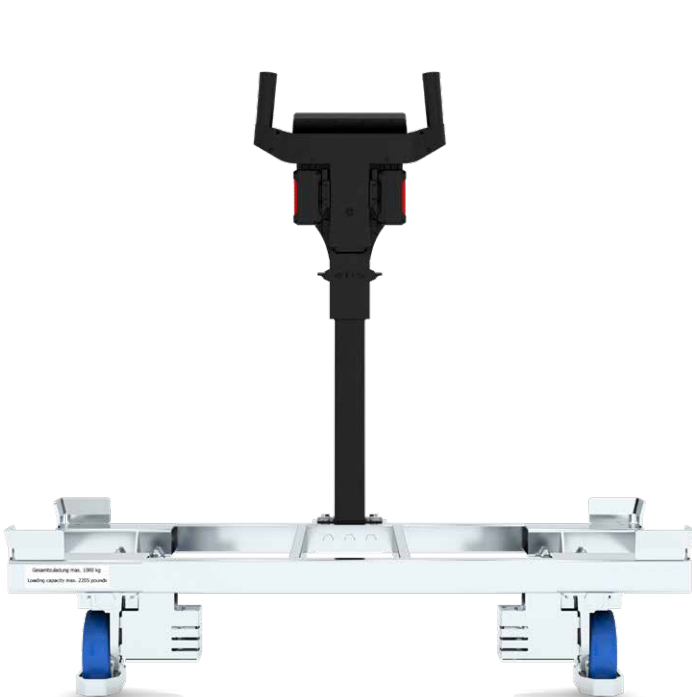
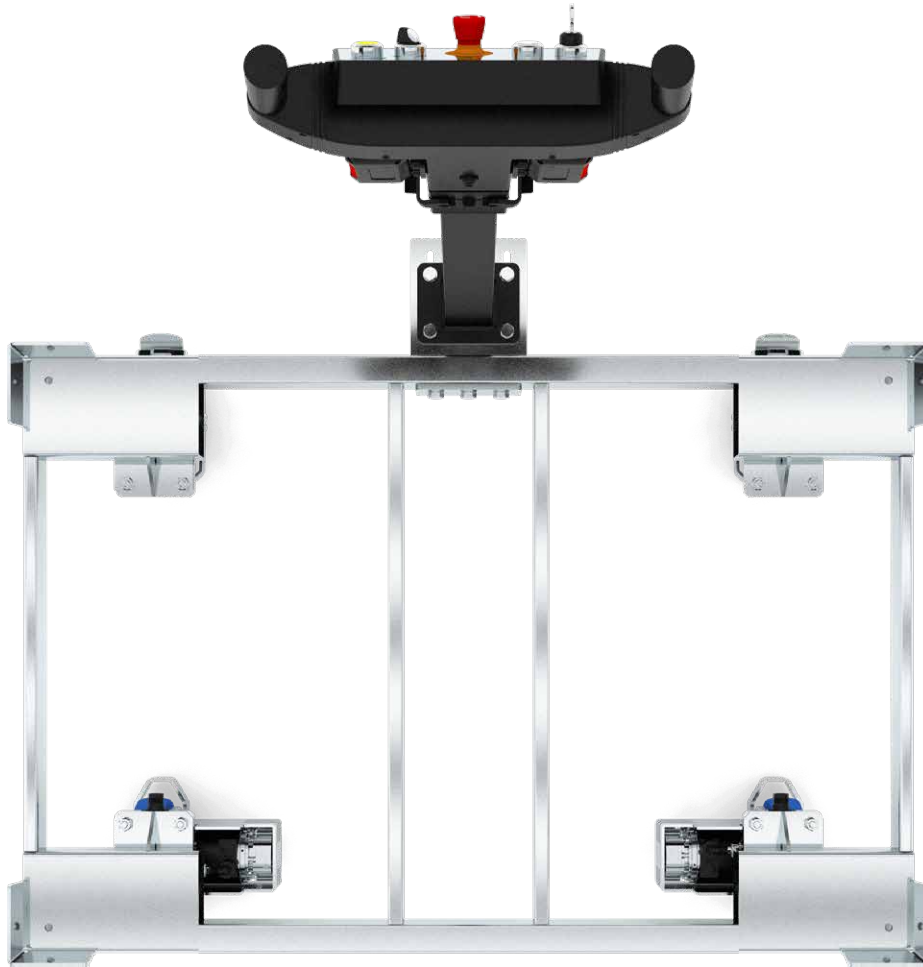

Products may differ from illustrations shown



COMBINATION WITH GANTRY TROLLEY



It is perfect for transport in a tugging train when combined with our electric gantry trolley. This gives an interesting possibility to integrate it in a tugging train system.



DETACHABLE COCKPIT



The cockpit is removable and can be used on different trolleys, increasing flexibility and efficiency.

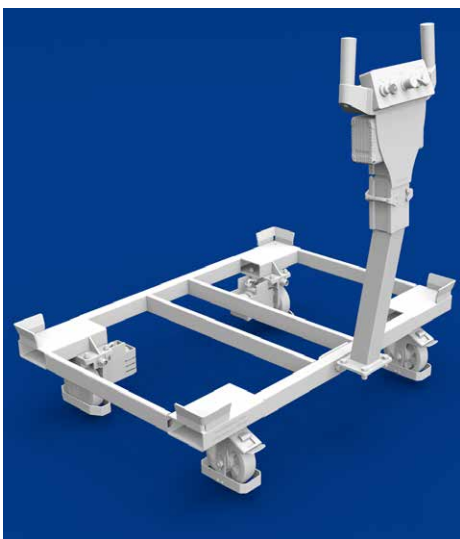

ELECTRIC DRIVE SYSTEM



This frame trolley for Euro-sized loads has an electric drive assistance system and can therefore be moved effortlessly by hand, whether empty or loaded.



DIMENSIONS (LxWxH):

- outside: approx. 1240 x 1025 x 1235 mm
- usable area: approx. 1210 x 810 mm
- usable area height: 262 mm
- track width: approx. 870 mm

CARGO LOAD:

- max. total trolley load:
1000kg (max. speed: 6 km/h))

CHARACTERISTICS:

- without coupling/drawbar system
- not stackable

CASTORS:

- 2 swivel castors with polyurethane tread
- 2 fixed castors with polyurethane tread
- 2 lockable castors
- wheel diameter: 160 mm
- Tread hardness: 75° Shore A
- Foot protection on all castors

ACCESSORIES:

- with insertion angle
- Prepared for top mounting
- with operating drawbar
- ESD-capable castors 10h7 Ohm
- with electric drive 24V 0,4 kW
- forward and reverse drive
- with pinch protection
- with emergency stop function
- with key switch
- with charging socket for external charger
(included in delivery)
- with charging indicator
- transport trolley lockable via locking device
on the castors

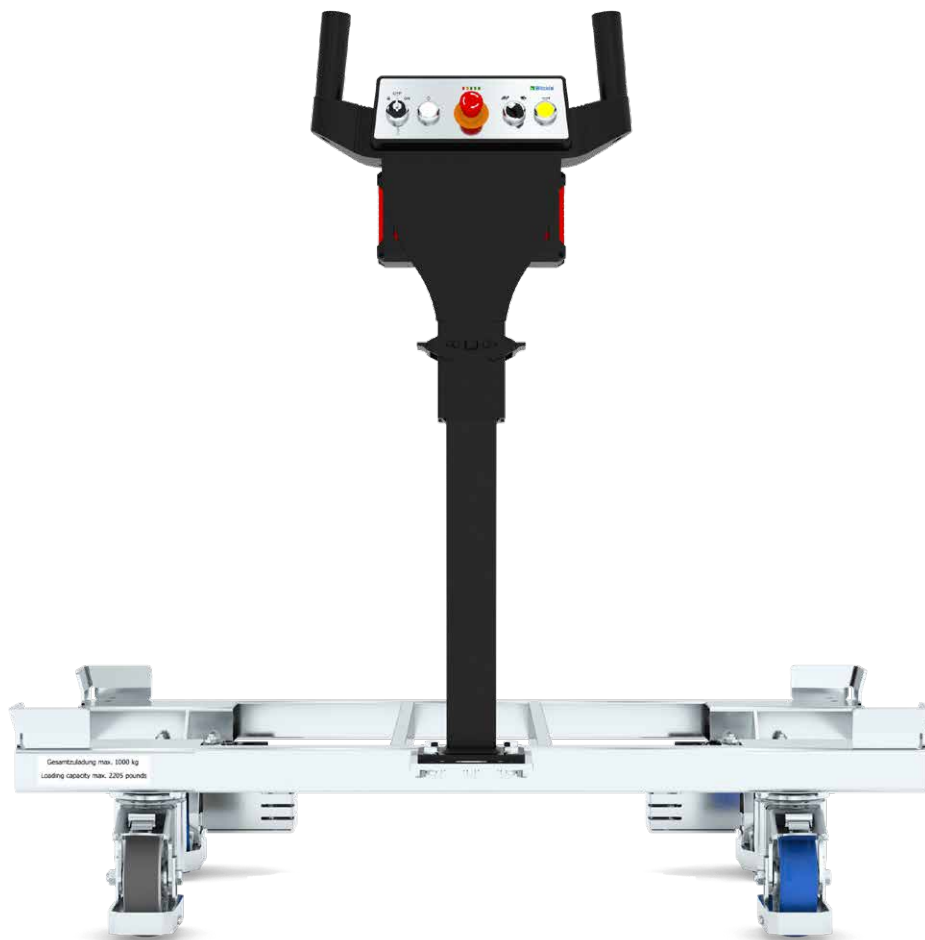

Products may differ from illustrations shown