

Products may differ from illustrations shown

The platform trolley for Euro-sized loads is equipped with an electric drive aid and can therefore be easily moved by hand. Depending on the equipment, loads of over 1,000 kg are possible.

It can also be used in a tugger train system as the powered castors have an idle function. The cockpit is optionally removable and can be used on different trolleys which provides for increased flexibility and efficiency. This offers an interesting possibility to integrate it into a tugger train system.

ELECTRIC DRIVE SYSTEM

EURO SIZE

ERGONOMIC

ROUTINE TRAINABLE

ROBUST

NIMBLE

Model	ART.-NO.	L x W x H outside	usable area height
Platform Trolley with Electrical Support	471-1294	approx. 1610 x 850 x 1270 mm	305 mm

PLATFORM TROLLEY WITH ELECTRICAL SUPPORT



Products may differ from illustrations shown



ELECTRICAL SUPPORT



Due to the electrical support this platform trolley can be moved easily and flexibly even outside the tugging train.

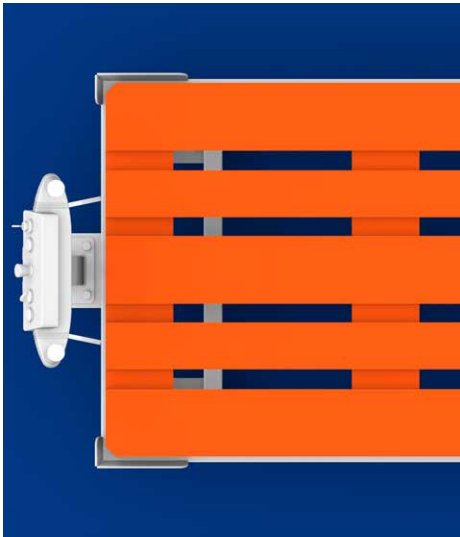

EURO SIZE

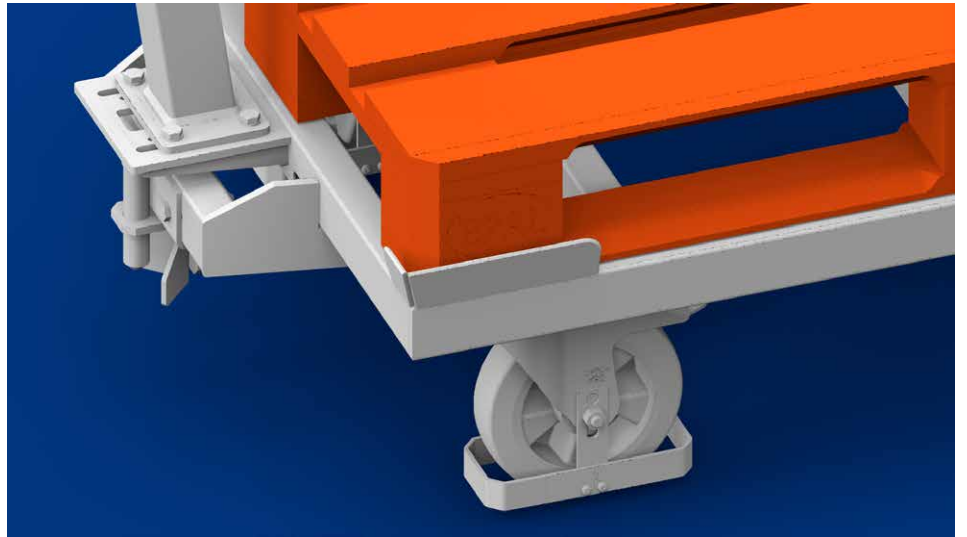

LKE platform trolleys with their proven industrial use are developed for the transport of pallets in Euro sizes. Alternatively, the transport of mesh pallets, industrial pallets, large pallets, etc. is possible.



COUPLING AND DRAWBAR SYSTEM

The drive castors have an idle function that makes the platform truck suitable for use in a tugging train system.



DIMENSIONS (LxWxH):

- exterior: approx. 1610 × 850 × 1270 mm
- Usable area: approx. 1212 × 812 mm
- Usable area height: 305 mm

TRAGLAST:

- max. total trolley load:
1000 kg (max. speed: 6 km/h)
- max. towing weight: 3000 kg

EIGENSCHAFTEN:

- virtual coupling / drawbar system
- not stackable

CASTORS:

- 2 swivel castors with polyurethane tread
- 2 fixed castors with polyurethane tread
- 2 castors lockable
- wheel diameter: 190 / 200 mm
- Tread hardness: 75° Shore A
- Foot protection on all castors

ACCESSORIES::

- with insertion angle
- ESD-capable via castors 10h7 Ohm
- with electric drive 24V 0,4 kW
- orward and reverse drive
- with anti-trap protection
- with emergency stop function
- with key switch
- with charging socket for external charger
(included in delivery)
- with charging indicator
- transport cart lockable via locking device
on the castors

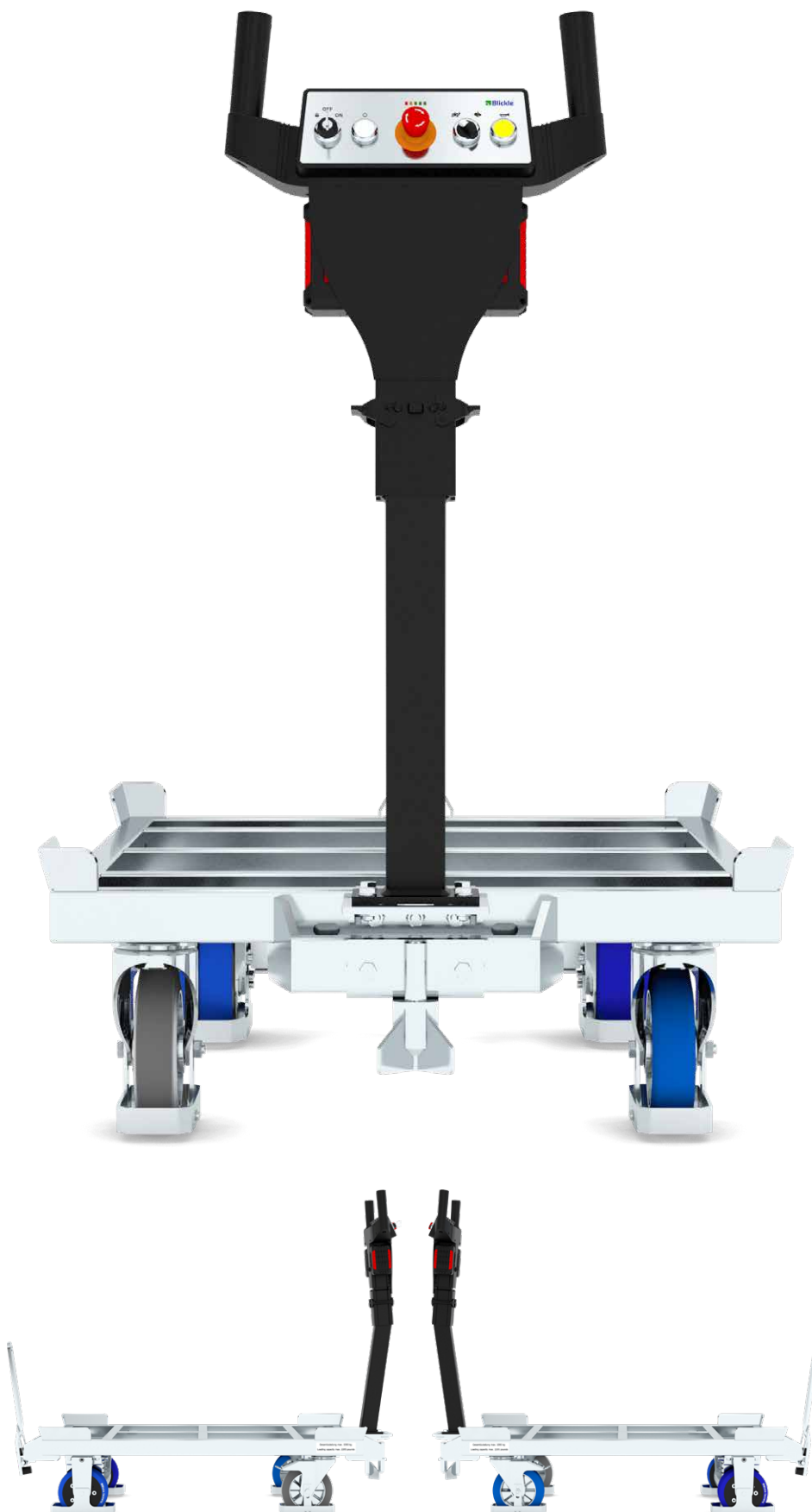

Products may differ from illustrations shown